

DN	Flansch Flange			Dichtungsleiste Jointing surface		Schrauben* Bolts*				Druckstufen Pressure stage			DIN EN 1092-2 ISO 7005-2	
	D	b	k	d1	f	Anzahl Number	Gewinde Thread	l	d2	PN	PN	PN	Norm Standard	
40	150	19,0	110	84	3	4	M16	70	19	10	16	25/40	DIN-EN	ISO
50	165	19,0	125	99	3	4	M16	70	19	10	16	25/40	DIN-EN	ISO
65	185	19,0	145	118	3	4	M16	70	19	10	16		DIN-EN	ISO
65	185	19,0	145	118	3	8	M16	70	19			25/40	DIN-EN	ISO
80	200	19,0	160	132	3	8	M16	70	19	10	16	25/40	DIN-EN	ISO
100	220	19,0	180	156	3	8	M16	70	19	10	16		DIN-EN	ISO
100	235	19,0	190	156	3	8	M20	75	23			25/40	DIN-EN	ISO
125	250	19,0	210	184	3	8	M16	70	19	10	16		DIN-EN	ISO
125	270	19,0	220	184	3	8	M24	80	28			25	DIN-EN	ISO
150	285	19,0	240	211	3	8	M20	75	23	10	16		DIN-EN	ISO
150	300	20,0	250	211	3	8	M24	80	28			25	DIN-EN	ISO
200	340	20,0	295	266	3	8	M20	75	23	10			DIN-EN	ISO
200	340	20,0	295	266	3	12	M20	75	23		16		DIN-EN	ISO
200	360	22,0	310	274	3	12	M24	90	28			25	DIN-EN	ISO
250	400	22,0	350	319	3	12	M20	80	23	10			DIN-EN	ISO
250	400	22,0	355	319	3	12	M24	90	28		16		DIN-EN	ISO
250	425	24,5	370	330	3	12	M27	90	31			25	DIN-EN	ISO
300	455	24,5	400	370	4	12	M20	90	23	10			DIN-EN	ISO
300	455	24,5	410	370	4	12	M24	90	28		16		DIN-EN	ISO
300	485	27,5	430	389	4	16	M27	100	31			25	DIN-EN	ISO
350	505	24,5	460	429	4	16	M20	90	23	10			DIN-EN	ISO
350	520	26,5	470	429	4	16	M24	100	28		16		DIN-EN	ISO
350	555	30,0	490	448	4	16	M30	110	34			25	DIN-EN	ISO
400	565	24,5	515	480	4	16	M24	90	28	10			DIN-EN	ISO
400	580	28,0	525	480	4	16	M27	100	31		16		DIN-EN	ISO
400	620	32,0	550	503	4	16	M33	120	37			25	DIN-EN	ISO

Hier kommen Flachdichtungen nach DIN-EN 1514-1 zum Einsatz.

* Schrauben nach DIN 931 / DIN EN 24014 / ISO 4014 / FGR 30 Schraubenlängen nach DIN 601 / DIN EN 24016

The use of flat gaskets acc. DIN EN 1514-1 are as standard.

* Bolts acc. DIN 931 / DIN EN 24014 / ISO 4014 / FGR 30 . Length of bolts acc. DIN 601 / DIN EN 24016

Flansch-Maße nach DIN-EN 1092-2 und ISO 7005-2
 Flange dimensions acc. DIN-EN 1092-2 and ISO 7005-2
 DN 500 – 1200

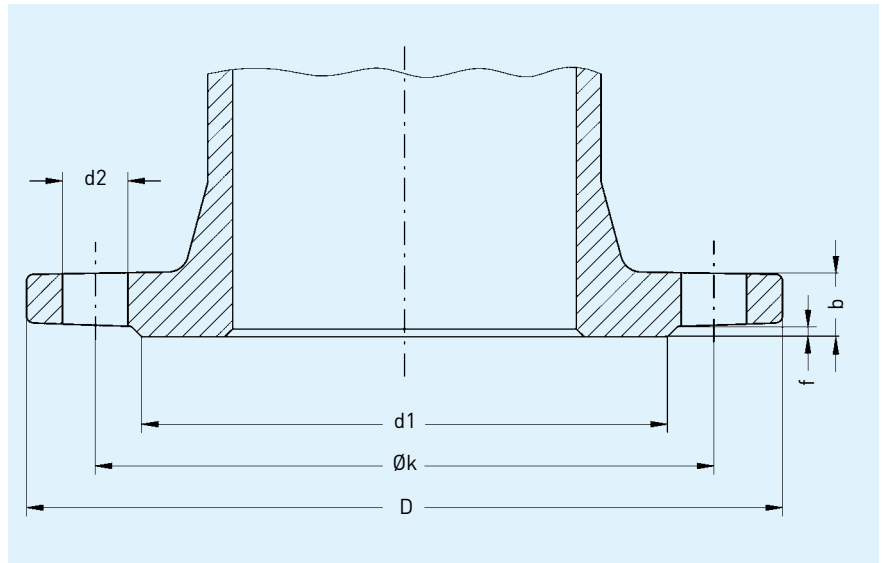

DN	Flansch Flange			Dichtungsleiste Jointing surface		Schrauben* Bolts*				Druckstufen Pressure stage			DIN EN 1092-2 ISO 7005-2	
	D	b	k	d1	f	Anzahl Number	Gewinde Thread	l	d2	PN	PN	PN	Norm Standard	
500	670	26,5	620	582	4	20	M24	100	28	10			DIN-EN	ISO
500	715	31,5	650	609	4	20	M30	110	34		16		DIN-EN	ISO
500	730	36,5	660	609	4	20	M33	130	37			25	DIN-EN	ISO
600	780	30,0	725	682	5	20	M27	110	31	10			DIN-EN	ISO
600	840	36,0	770	720	5	20	M33	130	37		16		DIN-EN	ISO
600	845	42,0	770	720	5	20	M36	140	41			25	DIN-EN	
600	845	42,0	770	720	5	20	M36	140	40			25		ISO
700	895	32,5	840	794	5	24	M27	110	31	10			DIN-EN	ISO
700	910	39,5	840	794	5	24	M33	130	37		16		DIN-EN	ISO
700	960	46,5	875	820	5	24	M39	150	43			25	DIN-EN	ISO
800	1015	35,0	950	901	5	24	M30	120	34	10			DIN-EN	ISO
800	1025	43,0	950	901	5	24	M36	140	41		16		DIN-EN	
800	1025	43,0	950	901	5	24	M36	140	40		16			ISO
800	1085	51,0	990	928	5	24	M45	170	50			25	DIN-EN	
800	1085	51,0	990	928	5	24	M45	170	49			25		ISO
900	1115	37,5	1050	1001	5	28	M30	130	34	10			DIN-EN	ISO
900	1125	46,5	1050	1001	5	28	M36	150	41		16		DIN-EN	
900	1125	46,5	1050	1001	5	28	M36	150	40		16			ISO
900	1185	55,5	1090	1028	5	28	M45	180	50			25	DIN-EN	
900	1185	55,5	1090	1028	5	28	M45	180	49			25		ISO
1000	1230	40,0	1160	1112	5	28	M33	140	37	10			DIN-EN	ISO
1000	1255	50,0	1170	1112	5	28	M39	160	44		16		DIN-EN	
1000	1255	50,0	1170	1112	5	28	M39	160	43		16			ISO
1000	1320	60,0	1210	1140	5	28	M52	190	57			25	DIN-EN	
1000	1320	60,0	1210	1140	5	28	M52	190	56			25		ISO
1200	1455	45,0	1380	1328	5	32	M36	150	41	10			DIN-EN	
1200	1455	45,0	1380	1328	5	32	M36	150	40	10				ISO
1200	1485	57,0	1390	1328	5	32	M45	180	50		16		DIN-EN	
1200	1485	57,0	1390	1328	5	32	M45	180	49		16			ISO
1200	1530	69,0	1420	1350	5	32	M52	210	57			25	DIN-EN	
1200	1530	69,0	1420	1350	5	32	M52	210	56			25		ISO