

Anpressflansch für Stahl- und Gussrohre* Pressure flange for Steel and Ductile pipes*

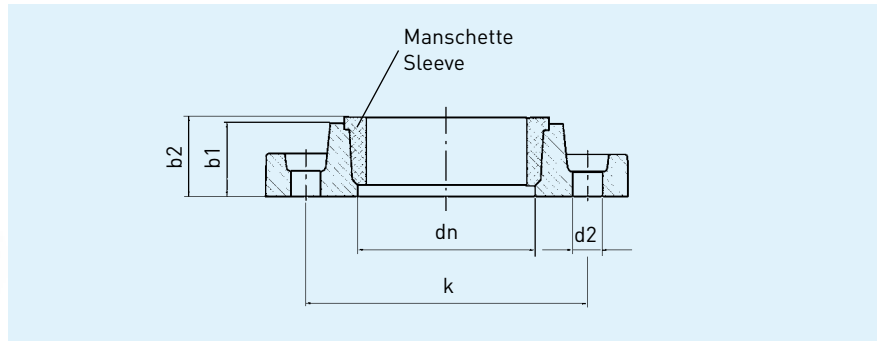

AF-ST, Anpressflansch für Stahlrohre AF-ST, Pressure flange for steel pipes

Maße in mm · dimensions in mm						kg/Stück kg/piece
DN	dn	b1	b2	k	d2	
200	219,1	42	44	295	23	9,1

AF-G, Anpressflansch für Gussrohre AF-G, Pressure flange for ductile pipes

Maße in mm · dimensions in mm						kg/Stück kg/piece
DN	dn	b1	b2	k	d2	
80	98,0	35	37	160	18	2,5
100	118,0	37	39	180	18	3,7
125	144,0	38	40	210	18	4,8
150	170,0	41	43	240	23	5,5
200	222,0	42	44	295	23	8,4
250	274,0	46	48	350	23	13,3
300	326,0	48	50	400	23	13,5

*Programm läuft aus
Werkstoff: duktiles Gusseisen
Beschichtung: EWS
Bohrbilder ab DN 200 ändern sich bei Druckstufe PN 16

*Programm will expire
Material: Ductile cast iron
Coating: EWS (fusion bonded epoxy)
The drilling template changes at DN 200 and larger for pressure rate PN 16