

FFK-Stücke 11°, PN 10/16 (25 und 40 auf Anfrage), Flanschbogen 11° nach FGR 71 oder Werksnorm  
 Double flanged bend 11° / 1/32, PN 10/16 (25 and 40 upon request), according to FGR 71 or factory standard

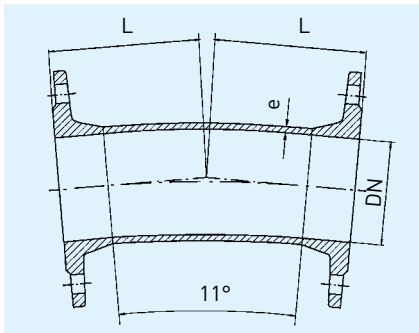

DN	Maße in mm · dimensions in mm		kg/Stück kg/piece
	L	e	
40	140	7,0	7,0
50	150	7,0	9,0
65	165	7,0	12,0
80	120	7,0	9,6
100	140	7,2	12,2
125	150	7,5	15,5
150	160	7,8	22,4
200	180	8,4	32,5
250	210	9,0	41,5
300	255	9,6	60,9
350	105	10,2	57,2
400	220	10,8	97,9
500	135	12,0	106,9
600	174	13,2	170,0
700	194	14,4	292,0
800	213	15,6	321,8

Achtung! Bohrbilder ab DN 200 ändern sich bei Druckstufe PN 16!

Attention! At pressure stage PN 16 drilling changes from DN 200!

FFK 22°

FFK-Stücke 22°, PN 10/16 (25 und 40 auf Anfrage), Flanschbogen 22° nach FGR 71 oder Werksnorm  
 Double flanged bend 22° / 1/16, PN 10/16 (25 and 40 upon request), according to FGR 71 or factory standard

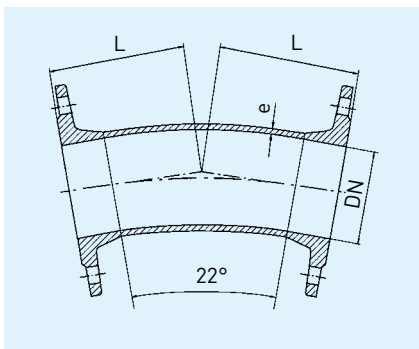

DN	Maße in mm · dimensions in mm		kg/Stück kg/piece
	L	e	
40	140	7,0	7,0
50	150	7,0	7,4
65	165	7,0	12,0
80	120	7,0	9,7
100	140	7,2	12,5
125	150	7,5	15,7
150	160	7,8	22,5
200	180	8,4	33,5
250	210	9,0	41,5
300	255	9,6	68,2
350	140	10,2	63,7
400	270	10,8	108,9
500	185	12,0	125,8
600	254	13,2	203,0
700	284	14,4	327,0
800	314	15,6	418,0

Achtung! Bohrbilder ab DN 200 ändern sich bei Druckstufe PN 16!

Attention! At pressure stage PN 16 drilling changes from DN 200!